

EU Declaration of Conformity No. SAR/Q001



Specialist Access & Rescue
Products Ltd.

This declaration of conformity is issued by Specialist Access & Rescue Products Ltd.
Of Sarena House, Vulcan Street, Oldham, OL1 4LQ

We hereby declare that:

Equipment: SAR Quad
Models: Quadpod

is in conformity with PPE EU Regulations 2016/425, as well as the applicable requirements of
the following standards (where applicable)

Ref No.

EN795:2012 Type-B
PD CEN/TS 16415:2013 Type B

Notified body: SGS FIMKO OY, Takomotie 8, FI-00380 Helsinki, Finland.
Notified Body No: C€ 0598

Performed the EU type examination and issued the EC type examination certificate number:

0598/PPE/24/3883 Issue 1

The PPE is subject to the conformity assessment procedure. Conformity to type Based on Quality Assurance of the Production Process Module D. Under the surveillance of the above Notified Body.

Signed by:

Name: Lee Allport
Position: Operations Director
Done At: SAR Products - Sarena House, Vulcan Street, Oldham, OL1 4LQ
On: 22/07/24

UKCA Declaration of Conformity No. SAR/UK/Q001



Specialist Access & Rescue
Products Ltd.

This declaration of conformity is issued by Specialist Access & Rescue Products Ltd.
Of Sarena House, Vulcan Street, Oldham, OL1 4LQ

We hereby declare that:

Equipment: SAR Quad
Models: Quadpod

is in conformity with PPE EU Regulations 2016/425, as well as the applicable requirements of the following standards (where applicable)

Ref No.

EN795:2012 Type-B
PD CEN/TS 16415:2013 Type B

Approved body: SGS United Kingdom Limited
Rossmore Business Park, Ellesmere Port, Cheshire, CH65 3EN

Approved Body No:  0120

Performed the EU type examination and issued the EC type examination certificate number:

0120/PPE/240255 Issue 1

The PPE is subject to the conformity assessment procedure. Conformity to type Based on Quality Assurance of the Production Process Module D. Under the surveillance of the above Notified Body.

Signed by:

Name: Lee Allport
Position: Operations Director
Done At: SAR Products - Sarena House, Vulcan Street, Oldham, OL1 4LQ
On: 22/07/24

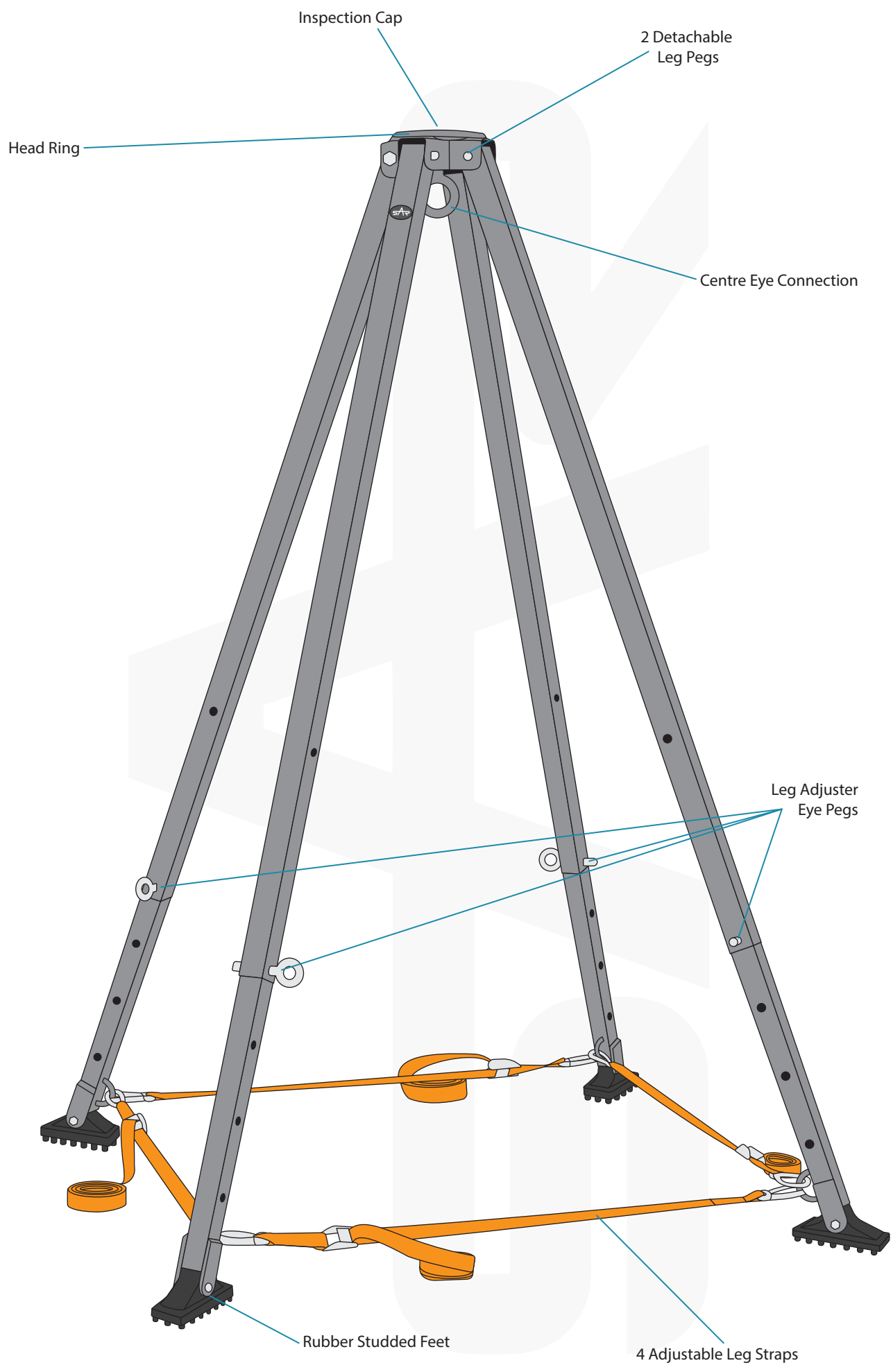

Product Record

This documentation should be issued with, and kept for, each item or system. Please see the product label for the details required below. Consult this guide for advice on inspection, maintenance, lifespan, etc.

Owner / User's Name:		
Date of Manufacture:	Date of Purchase:	Product Serial No.:
Date of First Used:		

Inspection & Maintenance Record

Date & Time	Type of Inspection & Comments	Name & Signature of Inspector	Next Inspection Due

Declaration Of Conformity

The EU Declaration of conformity is available by scanning the QR code or visiting - www.sar-products.com/eu-doc/



Certificate Of Conformity

We certify that the Quadpod conforms to EN796:2012 Type B & CEN/TS 16415:2013 Type B. Other components used with this product must conform to the relevant EN standards.

Signature:..... For SAR Products Ltd



User Guide:
Quadpod



Conforms to:
EN795:2012 Type B & CEN/TS 16415:2013 Type B

UK CA 0120 CE0598

sar-products.com
+44 (0)161 621 0309
sales@sar-products.com

Specialist Access & Rescue Products Ltd.
Sarena House, Vulcan Street, Oldham, OL1 4LQ
+44 (0)161 621 0309 | www.sar-products.com | sales@sar-products.com

The SAR Quadpod conforms to:

CE0598 & UKCA0120, EN795:2012 Type B for a one person load centre eye and outer ring.

CEN/TS 16415:2013 Type B for a 2 person load outer ring only.

CEN/TS 16415:2013 Type B for a 4 person load centre eye only.

Note: The information in this guide meets the requirements of the EU PPE Regulation 2016/425. It is not comprehensive and cannot be substituted for the correct training, which can be provided if required. If in any doubt, contact SAR Products using the supplied information.

When the Quadpod is used above a one person load then this is not classed as PPE and therefore does not fall under the PPE Regulation 2016/425.

Design

The Quadpod was designed specifically for technical rescue. It is far more adaptable than a normal tripod in the industrial environment. It enables the user to access many areas a tripod or other devices cannot. We strongly advise the user to be trained in its many uses and learn about its physical strengths and weaknesses.

Use

The Quadpod has been designed as a removable elevated anchor point as shown in the positions below. The positions and the working load limits must be followed at all times to be compliant to the standards list above.

The Quadpod should be assembled by a competent person or organisation.

The Quadpod should only be used for personal fall protection equipment and not for lifting equipment.

When the Quadpod is used as part of a fall arrest system then the user must use a device that will limit the impact force to 6kN.

Weights must be taken into consideration or calculated before the Quadpod is used.

During normal operating conditions and under the guidelines set out in this user guide, there will be no deflection or deformation.

Consideration to the surface the Quadpod will be used on must be taken into account, for example: Can the ground take the loading that will be applied and is the ground uneven? The feet must be as flat as possible on the ground, failure to check may result in dramatically lower working load limits.

The Quadpod can also be used in many other positions which are described further on.

The Quadpod can be used as an anchor in the following recommended modes conforming to the standards above:

1. Standard pyramid, Short front legs, long back legs, short back legs, long front legs as in diagrams A, B & C.

Diagram A

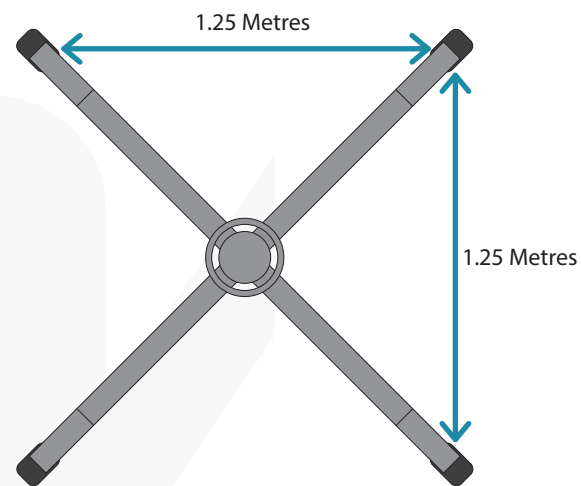

Diagram B

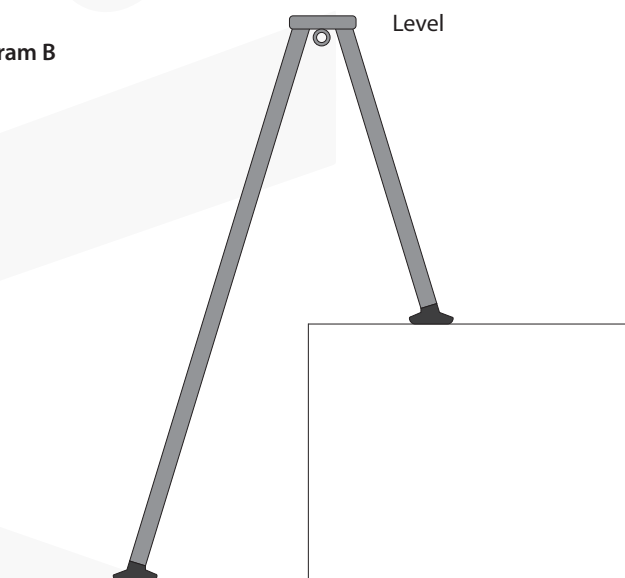

Diagram C



Working load limits of the Quadpod

The working load limit refers to the total load limit the Quadpod can be used with in diagrams A, B & C.

The working load limit for a static load used with the Quadpod is 400Kg. Where dynamic loads are to be used, please refer to the standard and the part of the Quadpod that has been tested for these loads.

1. CE0598 & UKCA0120, EN795:2012 Type B for a one person (100Kg) load centre eye and outside ring.
2. CEN/TS 16415:2013 Type B for a 2 person (200Kg) load outer ring only.
3. CEN/TS 16415:2013 Type B for a 4 person (400Kg) load centre eye only.

Breaking load limits

For a single person load EN795 the minimum breaking strength is 12kN. The centre eye meets these requirements when used in the positions in diagrams A, B & C.

For a 2 person load CEN/TS 16415/2013 the minimum breaking strength is 13kN. The outer ring meets these requirements when used in the positions in diagrams A, B & C.

For a 4 person load CEN/TS 16415/2013 the minimum breaking strength is 15kN. The centre eye only meets these requirements when used in the positions in diagrams A, B & C.

Assembling the Quadpod

The Quadpod must be assembled in a safe area before use. It is the responsibility of the user to ensure their own safety when doing so.

Inspection and Maintenance

- Before and after every use.
- Check all the locking nuts are secure.
- All retaining pins are in place.
- Ensure the eye bolt at the head of the Quadpod is free of dirt and free in movement.
- Check the rubber feet are free from defects.

After use wipe down any excess moisture and coat pins and bolts in light machine oil wiping away any excess oil.

Maintenance and inspections should only be carried out by a competent person at least every 6 months.

Warning

Always remain within the foot print of the Quadpod when set up as a removable anchor point and always remain below the anchor point, this will minimise a pendulum fall onto the anchor point which could potentially make the Quadpod unstable.

The Quadpod adjustable webbing leg straps must be used at all times.

Setting up the Quadpod

1. Set the Quadpod up as required.
2. Adjust the legs to the correct height and width and lock the legs into position using the eye bolt pins. Ensure as to not catch the fingers when doing so and always place the R clip in to the end of the pins.
3. Connect the Quadpod adjuster buckles between the legs, These need to be clipped into the small U bolts at the bottom of the legs and must be used at all times.
4. Pull the strap through buckle as in figure 1.
5. Press inner buckle clamp to release in figure 2.

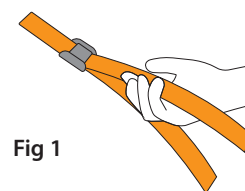

Fig 1

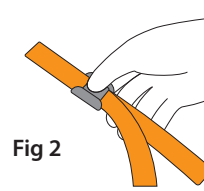

Fig 2

6. When using the Quadpod as a standard pyramid as in diagrams A, B & C always use the centre eye when possible.

Specifications

Materials & Coatings:

Legs: Aluminium powder coated.

Head: Stainless steel powder coated.

Bolts & Pins: Stn. steel, Mild steel, Nickel plated

Straps: Polyester webbing.

Weight

Quadpod only: 12.8Kg

Leg Securing Straps: 1Kg

Storage Bag: 0.5Kg

Meanings Of Markings

- The name, trademark or any other means of identification provided by the manufacturer or supplier.
- The batch or serial number
- Date of Manufacture (DoM)
- UKCA &/or CE mark with approved &/or notified body number
- The British &/ or EN standard(s) to which the item conforms
- Product description and/or reference
- Evaluation of capacity in Kg

Notified body

SGS FIMKO OY, Takomotie 8, FI-00380 Helsinki, Finland.

Notified Body No: 0598

Approved Body UKCA

SGS United Kingdom Limited

Rossmore Business Park, Ellesmere Port, Cheshire, CH65 3EN

Approved Body No: 0120

The Quadpod can be used in other positions as shown below.

The positions show below do not fall under the test requirements of the above standards and careful consideration and calculations of loads must be taken into account by the users before carrying out any tasks.

1. Offset pyramid
2. Half pyramid
3. Overhanging



Settings 1, 2, & 3 do not fall under the test requirements for EN795 and CEN/TS 16415. Option 2 & 3 positions must be anchored and the anchors strong enough to conform to the standard 15kN.

1. The offset pyramid is best for tensioned cable lines using the central connecting eye for your pulley. The reason for this is the force down should be central to the Quadpod when you dissect the angle. Another pulley can be fitted under the cable pulley or pulleys for the hauling.
2. When using the half pyramid or overhang setting for cliff or edge rescue, you should use the front outer ring connecting point. By fitting a Dee Mallion to the ring, then a karabiner for the pulley or a Delta Mallion for twin pulleys. The angle of the load will be central to the Quadpod and there should be no need to fasten down to secure the legs. In these positions you MUST use a back securing rope from a firm anchor to the top back outer ring prior to load being put onto the system.

When using a guide rope all connectors must conform to EN362. A guide rope should only be connected to the outer ring and no other part of the Quadpod.

SAR Products strongly recommend training on using the Quadpod.

Product Record

This documentation should be issued with and kept for each item or system. Please see the product label for the details required below. Consult this guide for advice on inspection, maintenance, lifespan, etc.

Owner / User's Name:			
Date of Manufacture:		Date of Purchase:	
Date of First Used:		Product Serial No.:	

Inspection & Maintenance Record

Date & Time	Type of Inspection & Comments	Name & Signature of Inspector	Next Inspection Due

A digital copy of these User Instructions is available by scanning the QR code.



Specialist Access & Rescue
Products Ltd.

General User Instructions

General

User Instructions

WARNING

Please read and understand these instructions before use. For complete information, the user must also read the instructions for the specific product being used.

Working at height and rescue are hazardous. It is the user's responsibility to ensure understanding of the correct and safe use of this equipment, to use it only for the purposes for which it is designed and to practise all proper safety procedures.

If there is any doubt about the correct use of this products, the user should contact SAR Products for advice and clarification.

Use

This equipment must be used in line with this user guide and any instruction given by an authorised trainer. Users should be trained and competent, or under the supervision of such a person. The information in the user guide is not comprehensive and cannot be substituted for the correct training, which can be provided if required.

All equipment and components manufactured or supplied by SAR Products Ltd meet or exceed the relevant European or International Standard. Where no relevant Standard applies, the product is still subject to the same high quality manufacturing & testing processes. If the product is sold outside of the original country of sale, it is the re-seller's responsibility to supply this and other relevant documentation in the language of re-sale.

A Risk Assessment and Rescue Plan should always be in place for any work at height. All components not part of the original system should be checked for their compatibility and compliance with the relevant Standards. The manufacturer should be consulted if there is any doubt. Attention should be paid to the loads that are to be applied to any component or system and MUST NOT exceed the manufactures recommendation or value calculated using the appropriate safety factor.

Safety

The safety provided by any product used for fall prevention or rescue is dependant on many factors, including scenario, suitability for task, environment, competence of the user, etc.

The user must ensure that the equipment is used for the purpose for which it was designed, and not outside its capabilities. The strength and suitability will be reduced through factors such as, but not limited to, age, wear & tear, abrasion, cuts, high impact loads, tight/sharp edges, knots, some chemicals (e.g. strong alkalis), UV exposure, failure to store & maintain as recommended, etc.

Do not alter the product in any way. Any component subjected to a dynamic loading should be examined and discarded if there is any sign of defect, or any doubts about its safety.

Cleaning

Rinse in clean cold water. If still soiled, textiles may be washed in clean warm water (max. 40°C) with pure soap or a mild detergent (within pH range of 5.5 to 8.5). Rinse thoroughly in clean cold water. Metal and hard plastic components may be power washed with a low pressure setting.

Maintenance

Always keep the product clean and dry. Any excess moisture should be removed with a clean cloth and then allowed to dry naturally in a warm room away from direct heat.
Metal components may be lubricated with a dry PTFE lubricant or WD40 type spray. Excess lubricant should be wiped off to avoid attracting excess dirt.

Inspection

Before each use, conduct a visual inspection and function test to ensure the product is in serviceable condition and operates correctly. A thorough examination should be carried out at by a competent person least every 6 months. These inspections should be recorded, paying particular attention to areas of potentially high wear such as attachment points, textiles, cams, bearings, etc.

Textiles: Check for cuts, tears, and abrasions, damage due to deterioration, contact with heat, alkalis or other corrosives.

Sewing: Check for broken, cut or worn threads.

Metal: Check for cracks, distortion, corrosion, wear by abrasion, burrs, worn or loose rivets or screws, discolouration caused by extreme heat (greater than 100° C) broken springs, seizure of moving parts, broken or missing components.

Immediately withdraw from service any items showing defects. Any repairs must be carried out by the manufacturer or their authorised agent.

No alterations/modifications to the equipment must be made without the authorisation of the manufacturer.

Storage

After cleaning, store unpacked in a cool, dry, dark place away from excessive heat sources or other possible causes of damage. Do not store wet.

Transport in a suitable bag.

Chemicals

Avoid contact with any chemicals which could affect the performance of the product. If contact occurs, or is suspected, then remove the product from service immediately.

If used in a marine environment, thoroughly rinse in clean cold water and dry after each use.

Lifespan

The lifespan of any product will be affected by the conditions in which it is used and stored/ maintained.

Textile Components should be retired no later than 10 years after the date of manufacture.

Metal components will have an indefinite lifespan, depending on use.

The working life will be reduced through general wear and tear, abrasion, cuts, damage to component parts, inappropriate ancillary equipment, high impact load, prolonged exposure to UV light including sunlight, elevated temperature (50° C max), exposure to some chemicals (e.g. strong alkalis) or failure to store and maintain as recommended. This list is not exhaustive.

The working life of any product may be as little as a single use in extreme conditions.

Meanings of Markings



The name, trademark or any other means of identification provided by the manufacturer or supplier.

XXXXXX

The batch or serial number

XX/XX

The month & year of manufacture

CEXXX

CE... EC logo followed by the number of the notified body

UKXXX

UKCA... logo followed by the number of the approved body

ENXXX:XXXX

EN... European standard attributed to this PPE



Pictogram informing the user to read the instructions